



Warman XU Pump

Medium Duty Slurry Pump

The Warman XU metal pump's many unique features ensure lowest ownership cost in arduous slurry applications.



A cost effective and easy to maintain pump

The Warman XU pump includes unique casing, impeller and sealing design to ensure lowest possible wear rates in sand and gravel, coal, and many other medium to coarse slurry applications.

The XU supercedes the AHU unlined pump, and is in most cases dimensionally interchangeable, fitting directly onto the tried and proven Warman bearing assembly and base.

The XU's unique design is not only cost effective, but easy to maintain.

Excellent
Engineering
Solutions



Warman XU is the result of the latest fluid dynamics techniques, advanced computer wear modeling, years of field and lab testing, and decades of design experience.

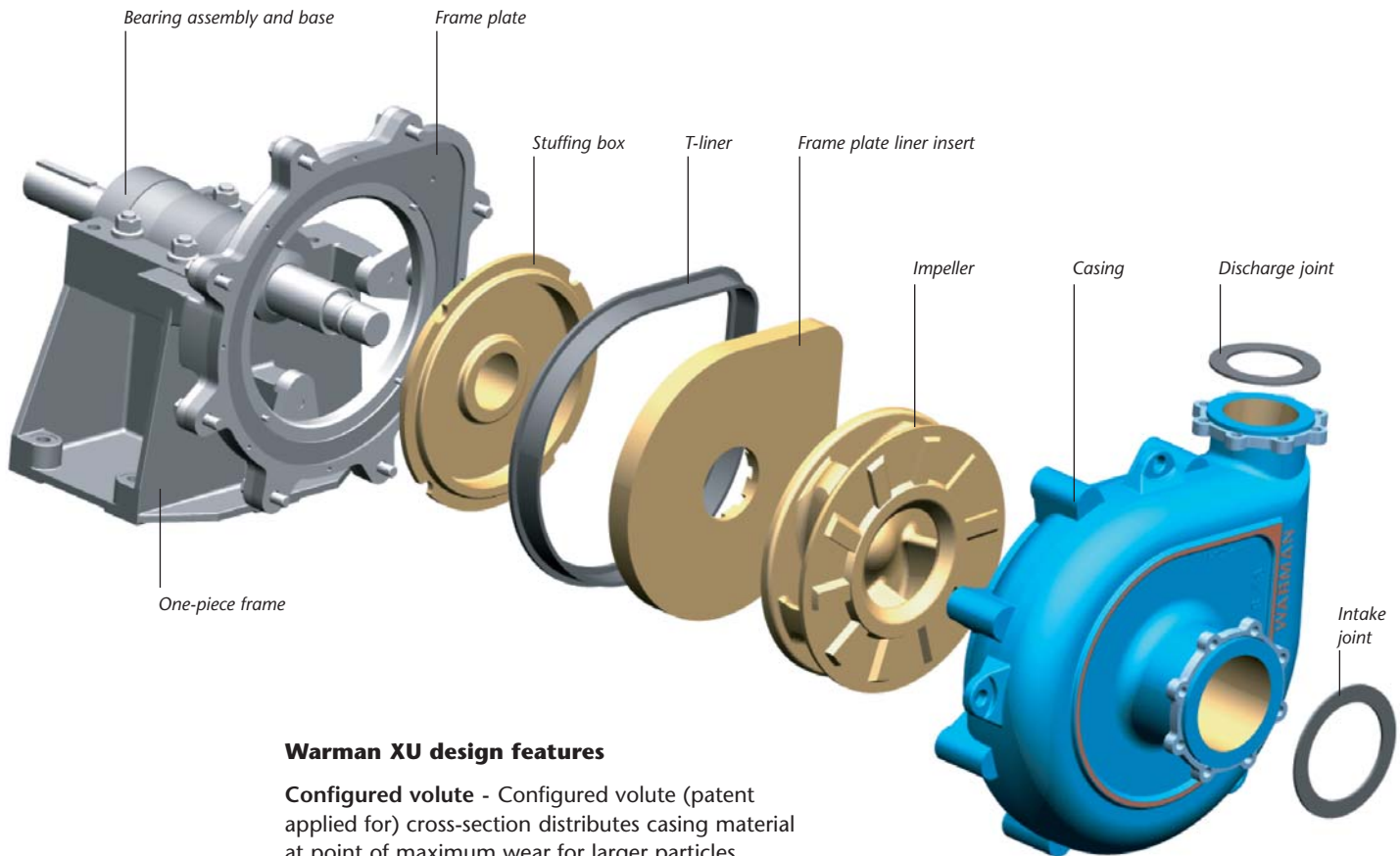

Warman XU design features

Configured volute - Configured volute (patent applied for) cross-section distributes casing material at point of maximum wear for larger particles.

Low V cutwater - Low V open cutwater design lowers slurry velocity and consequent wear and prevents separation at flows less than BEP. Low V design also produces more forgiving operating range and broader efficiency band.

Impeller wear ring - Patented impeller wear ring profile reduces wear on the throatbush and impeller by reducing turbulence and restricting recirculation.

Extended shroud impeller - Unique (patent applied for) extended shroud impeller design reduces side-liner wear by trapping the pump-out vane tip vortices against the shroud preventing further vortex development.

Profiled impeller tip - Unique (patent applied for) impeller vane tip profile increased radial velocity of flow in center of vane preventing inward spiral flow and reducing wear in the casing.

“Tear drop” frame liner - Unique (patent applied for) frame plate liner insert shape ensures any local side wall wear occurs on the liner, not in the more expensive casing. Flat ceramic wear resistant inserts are options for very aggressive applications.

Ease of maintenance - Unique “T-liner” and spigot-fits ensure all components can be assembled easily. Casing has 3 shackle lifting points. Gland seal pump is easily converted to centrifugal seal by adding expeller and new shaft sleeve.

Centrifugal seal performance - Deep and efficient impeller pump out vanes combine with high ratios (85%) expeller diameter produce exceptional dry sealing performance

Expelling vane shape - Leading edge of expelling vane is a patented shape designed to reduce tip turbulence and maximize pressure reduction and sealing effect.

One-piece frame - A very robust one-piece frame cradles the cartridge type bearing and shaft assembly. An external impeller adjustment mechanism is provided below the bearing housing for easy adjustment of impeller clearance.

Unique design features ensure the Warman XU pump has the lowest ownership cost in its class.

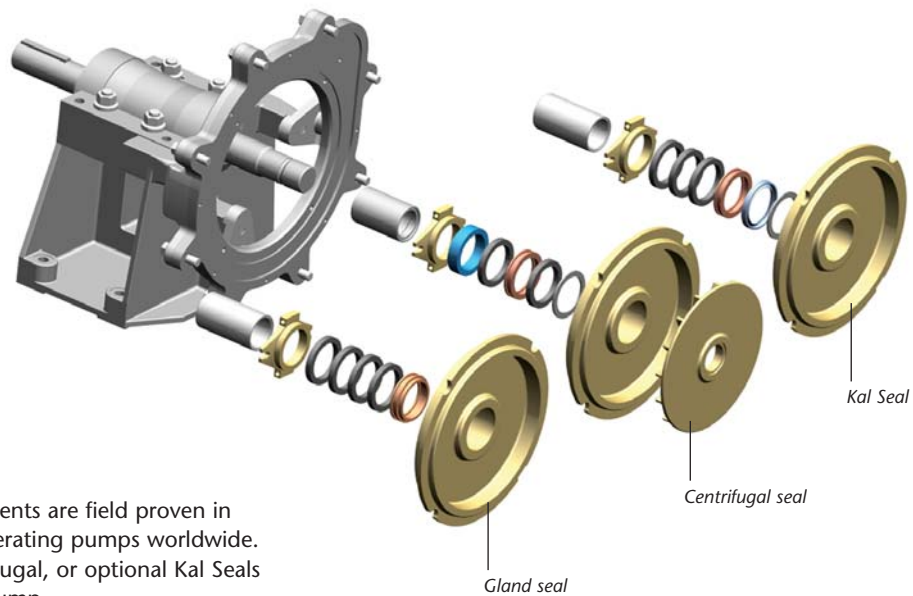

Our shaft sealing arrangements are field proven in thousands of successful operating pumps worldwide. Our standard gland, centrifugal, or optional Kal Seals may be fitted to any size pump.

Shaft sleeve

An easily removable shaft sleeve manufactured in either hardened steel or ceramic coated steel with o-ring seals at both ends protects the shaft from abrasive or corrosive contaminants.

Centrifugal seal

External gland sealing is available in most applications. Deep and efficient impeller pump out vanes combine with high ratios (85%) expeller diameter produce exceptional dry sealing performance

Kal Seal

The optional Kal Seal arrangement utilizes a lip seal located at the front of the box. Kal Seal prevents contamination of packing during gland water interruptions and reduces overall water consumption. A neck ring protects the lip seal.

Materials of Construction

Part	Material	Specification
Impeller	Ultrachrome	A05
Casing	Ultrachrome	A05
Frame plate liner insert	Ultrachrome	A05
Flanges	SG Iron	D21
Shaft sleeve	Martensitic SS	C21
Shaft	Carbon steel	E05
Stuffing box	Ultrachrome	A05
Expeller	Ultrachrome	A05

Applications

- Sand and gravel
- Coal
- Potash
- Phosphate
- Ash/dust
- Gold/copper
- Sugar
- Alumina



Dimensions

pump size	A* inches	B inches	C inches	D inches	U mm	key size mm	E inches	F* inches	G inches	H inches	J* inches	K inches	L inches	M* inches	N inches	P inches	wt./lbs. approx.
3/3 CXU	30.24	15.98	12.24	10.00	42	12x8	4.76	11.26	8.07	5.43	8.27	2.95	-	6.18	2.56	4.33	335
4/4 CXU	33.07	15.98	12.24	10.00	42	12x8	4.76	14.13	10.71	7.87	11.97	0.31	-	7.56	3.23	5.59	535
4/4 DXU	36.97	19.37	14.33	12.99	65	18x11	6.46	14.13	10.71	7.87	11.97	3.19	-	7.56	3.23	5.59	690
6/5 DXU	40.16	19.37	14.33	12.99	65	18X11	5.94	17.01	13.58	9.02	13.94	1.46	-	8.94	4.13	6.50	1070
6/5 EXU	46.26	24.49	17.64	17.99	80	22x14	8.07	17.36	13.58	9.02	13.94	6.46	-	8.94	4.49	6.50	1380
8/6 EXU	51.42	24.49	17.64	17.99	80	22x14	8.74	22.36	18.03	12.52	18.11	2.13	-	11.93	5.24	8.86	2260
8/6 FXU	59.41	33.74	25.00	24.02	100	28x16	10.98	21.65	18.03	12.52	18.11	8.15	-	11.93	4.53	8.86	2900
10/8 EXU	52.83	24.49	17.64	17.99	80	22x14	8.74	23.46	21.97	15.00	21.81	-	1.69	12.99	4.17	11.42	3300
10/8 FXU	60.67	33.74	25.00	24.02	100	28x16	10.98	23.03	21.97	15.00	21.81	4.33	-	12.99	3.70	11.42	3985
12/10 EXU	54.17	24.49	17.64	17.99	80	22x14	8.74	25.12	23.58	15.94	26.50	-	3.86	13.19	4.45	12.80	4385
12/10 FXU	62.24	33.74	25.00	24.02	100	28x16	10.98	24.57	23.58	15.94	26.50	2.17	-	13.19	3.90	12.80	5100
14/12 FXU	65.91	38.98	27.76	24.02	100	28x16	10.98	28.46	26.69	18.11	26.50	-	0.55	14.92	5.35	13.39	6315

* Dimension includes compression of Warman rubber joint.

Note: U dimensions and key sizes are in millimeters. All others are in inches. Dimensions are for reference only.

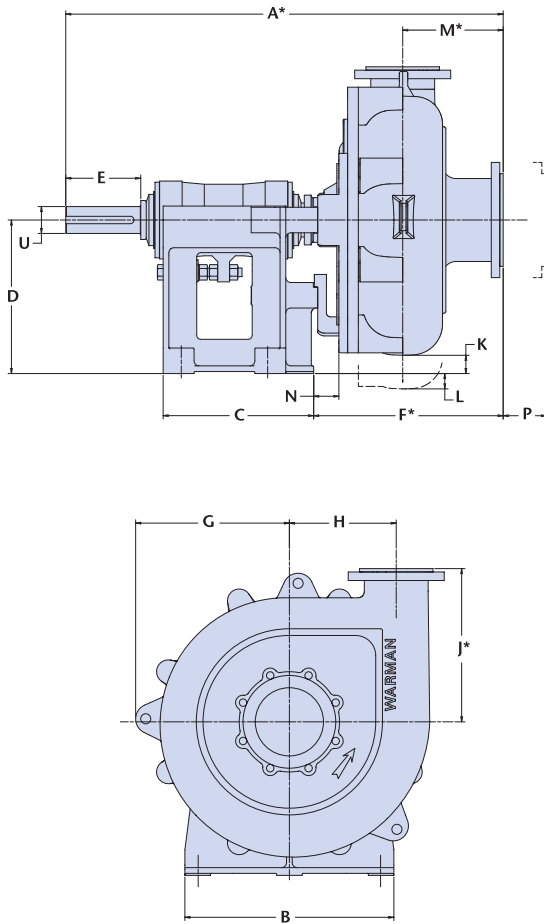

Warman XU Selection Chart

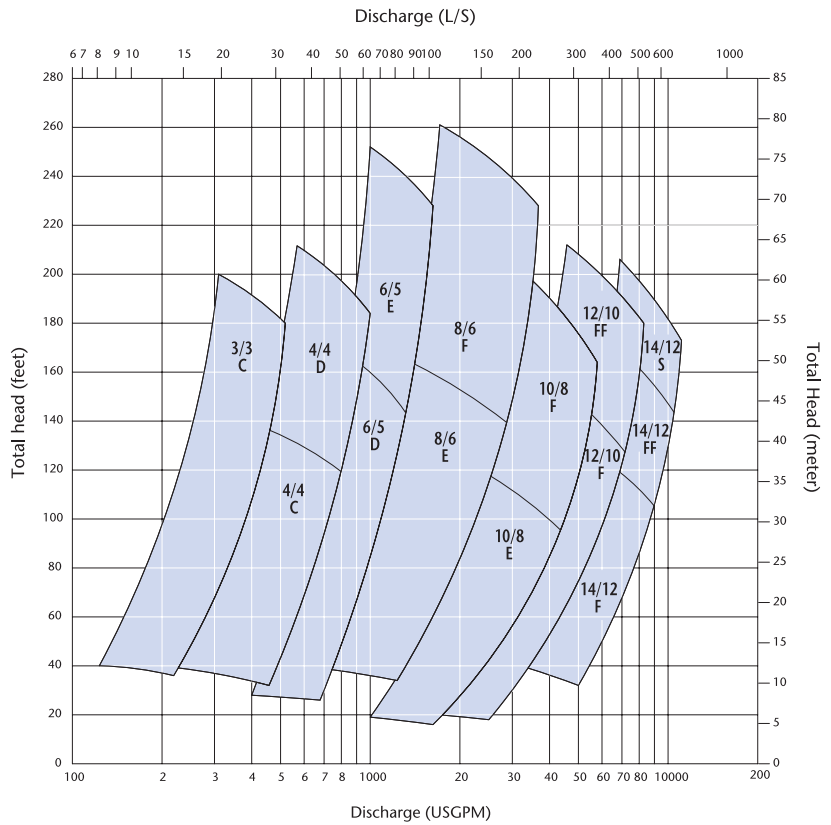

Most XU wet ends are interchangeable with Warman AH and AHU models. Please consult your local Weir Minerals representative for details.

Weir Slurry™
North America

2701 S Stoughton Road, Madison WI 53716
PO Box 7610, Madison WI 53703
USA

Tel: 608 221 2261
Fax: 608 221 5810
www.weirslurry.com

Excellent
Engineering
Solutions

WEIR
MINERALS