

GEHO PUMPS®

First choice
for innovative piston and piston diaphragm slurry pumps



Excellent
Engineering
Solutions

WEIR
MINERALS

Weir Netherlands b.v. – range of GEHO positive displacement pumps

GEHO PUMPS has the market leading capability to meet highly specific and challenging customer requirements as they move into new areas.



Each pump is passing a full load factory acceptance test to verify its mechanical and hydraulic performance.



Underlying our product capability is our implementation of Lean manufacturing principles. This delivers direct customer benefits, reduces lead times and ensures an optimum balance of product quality with value engineering.

Weir Netherlands b.v. designs, manufactures and markets piston and piston diaphragm pumps under the brand name GEHO PUMPS.

Since 1957 our company has pioneered hydro-transport, which is the hydraulic conveyance of solids in fluid mixtures referred to by different names such as slurry, sludge and paste. This brochure handles the different pump designs, their applications and our available support and services.

Slurry pumps are our core competency. We are committed to maintaining our hard-earned market and technological leadership. Existing and future customers enjoy the benefits of our ongoing support and product innovation. Close co-operation has resulted in challenging new slurry handling/disposal applications, a higher specific output and enhanced pump and system performance.

Our 280 staff are dedicated to research, development, slurry laboratory testing, pump systems, engineering, manufacture, customer services, field services, after sales, quality assurance and control.

The range of GEHO positive displacement pumps is complementary to the other slurry handling equipment supplied by the Weir Minerals division.

Weir Minerals division

Weir Netherlands b.v. is part of the Weir Minerals division, one of five divisions that form The Weir Group based in Scotland.

Weir Minerals has an advanced product range incorporating market leading brands covering virtually any application, in any environment.

Weir Minerals products account for 19% of market share world-wide.

Weir Minerals owns a valuable portfolio of intellectual property, which is continually being extended through research and development in materials and technology to enhance the wear life of its products. As a result, the global leadership in slurry pumps is combined with innovative designs in complementary products such as mill liners, hydrocyclones and slurry valves.

Weir Minerals has the geographical presence to service all major mineral markets around the world. This global supply capability provides a competitive advantage in this relatively fragmented market. Weir Minerals supports customer operations world-wide with consistent products and local engineering expertise.

GEHO PUMPS®



ASH PUMP®

Galigher®

HAZLETON

SCHABAUER

CAVEX®

WEIRESIST

IsoGate™

Consultancy and slurry testing

Consultancy

You are welcome to let our experts review your slurry pumping needs (application). Customers in the global mining, mineral processing and power industries usually call on GEHO PUMPS for advice in the development of a slurry processing system and in studying the technical and economic feasibility of a project.

We have considerable knowledge and experience in all aspects of slurry, ranging from sample testing, slurry characterisation, flow behaviour, pressure loss calculation and flow sheet optimisation to the selection and bidding of the appropriate pump. This consultancy work serves a mutual benefit and is usually provided free of charge, unless the required scope is extensive. It has enabled GEHO PUMPS to build each individual pump to suit a particular service and meet proprietary criteria for power end rating, diaphragm load, stroke rate, valve velocity, etc. We enjoy a lasting partnership with owners aimed at optimising the operation of their GEHO slurry pump. The pumpability, flow regime and behaviour of a slurry or paste are analysed based on the solids concentration, particle size distribution, rheology, Miller number, solids segregation and shearing characteristics determined in-house from slurry sample tests.

Our extensive rheology database, in-depth understanding, conceptual design work and online experience ensure a reliable definition and match of the operating envelope for your system and pump.

Pump selection guide

Where pumping of high concentration slurry, sludge or paste is required, it is best carried out by high pressure reciprocating positive displacement pumps. The selection of the appropriate pump type depends primarily on the viscosity and other characteristics of the slurry such as top particle size as well as cost and maintenance considerations.

Each of the six GEHO displacement pump types has distinct abilities and features. They handle the following applications:

- Slurry pipelines
- Mine dewatering and desludging
- Mine backfilling
- Tailings disposal
- Ash disposal
- Hydraulic ore hoisting
- Autoclave feed
- Digester feed
- Reactor feed
- Gasifier feed
- Incinerator feed
- Fluidized bed combustion feed
- Biomass reactor feed
- Municipal sludge transfer



Pump type	GEHO type	Viscosity (mPa.s)	Solids concentr. (%)	Particle size (mm)
Duplex crankshaft driven piston pump	ZPR	< 8.000	< 75	< 8
Triplex crankshaft driven piston pump	TZP	< 8.000	< 75	< 8
Duplex crankshaft driven piston diaphragm pump	ZPM	< 8.000	< 75	< 8
Triplex crankshaft driven piston diaphragm pump	TZPM	< 8.000	< 75	< 8
Hydraulic driven piston pump with valves	DHC	< 50.000	< 80	< 15
Hydraulic driven piston pump without valves	DHT	< 100.000	< 90	< 80

Mining and mineral processing typically involve abrasive slurries and rheology that make severe demands on the pumps used.

GEHO PUMPS has extensive experience in a wide variety of applications in the mining and mineral processing, power and waste treatment.

Product innovation

The piston pump, model ZPR, was developed in the 1960's in conjunction with municipalities to meet an emerging demand for the transport of sewage sludge. A large number of these early pumps are still in operation in Europe and elsewhere and transfer screened raw sludge, feed filter presses or pump drilling mud. Even today, municipal customers often prefer this double-acting crankshaft driven piston pump to ram pumps and hose-type piston diaphragm pumps.



We have supplied more than 10,000 wellpoint dewatering pumps over 50 years. These two-cylinder vacuum piston pumps lower the ground water table enabling excavations and civil construction under dry conditions. This particular engine-driven pump is for use in urban areas and is silenced to 48 dB(A). The noise hood and skid protect the pump against vandalism as well as flora, fauna and water quality against the spillage of oil and fuel.

The approach and attitude we take to business and product development continues from the entrepreneurial brothers Holthuis (GEHO) who founded the company in 1916. They transformed the company from a foundry to the design and manufacture of solids handling centrifugal pumps and piston pumps. The piston pumps proved their worth in the handling of mildly abrasive sludge and slurry. The company envisioned an emerging potential for pumps in which the abrasive product is hermetically sealed from the piston by means of a hydraulically actuated diaphragm. The sewage, steel, mining and mineral processing industries in the Europe of the 1970's actively supported GEHO PUMPS in this pioneering development and were rewarded with low parts usage and maintenance costs. The market recognition enabled GEHO PUMPS to rapidly expand the range and provide piston diaphragm pumps with increasing flow rate, pressure and temperature capability. Vast growing on-line experience, an in-depth knowledge of slurry and working with the various industries helped to improve the pump design and encouraged GEHO PUMPS to explore new applications. This often required a detailed involvement in the process flow sheet and the supply of associated plant and equipment.



The reliability of the diaphragm and its position controls was verified in 1973 by operating a ZPM 500 on red mud at VAW. The alumina refinery in Germany then challenged GEHO PUMPS to build a large 325 m³/h capacity digester feed pump handling 90°C bauxite against 13,000 kPa. The tremendous up scaling to a ZPM 1500 was not without difficulty and a number of modifications were made. These pumps were a major break-through in technology and market recognition. They enabled GEHO PUMPS to reliably expand the range.

Some striking examples of pioneering first applications, which have helped the industry to operate more efficiently and cleanly, include:

- 1975 – digester feed at VAW, Germany
- 1979 – red mud disposal at KAP, Montenegro
- 1981 – gasifier feed at Eastman Chemical Co., USA
- 1983 – mine backfill at Minas de Arcata, Peru
- 1983 – iron ore mainline pumps at OEMK, Russia
- 1989 – 155°C autoclave feed at Barrick, USA
- 1991 – 25 MPa mainline pumps at Simplot, USA
- 1995 – fly ash slurry pipeline at Bayswater Power Station, Australia
- 1998 – 200°C autoclave feed at Murrin Murrin, Australia

Hydraulic driven pumps of industrial design and quality were added to the product portfolio in the 1980's – the most extensive range of crankshaft driven piston and piston diaphragm pumps and hydraulic driven pumps. The production of mud pumps and concrete pumps was given up to concentrate our focus on slurry pumps. It was inevitable to this development process that the load on the pumps gradually increased and limits were empirically determined. The lessons learned have been instrumental in the current designs and our application guidelines. Our responsive organization and intimate customer relations remain critical to future product improvement and extending the pump design envelope.



Knowledge and experience culminated in this 208°C autoclave feed pump for Rio Tuba. It features a slide-mounted pump, Titanium water end, droplegs with separator and cooling jacket and top-mounted Outlast® valves.

TZP – Triplex single-acting crankshaft driven piston pump

The TZP is a three-cylinder single-acting crankshaft driven piston pump. The principal difference to a ZPR is the single-acting piston. The TZP does not use a stuffing box. It reduces the number of wear parts and makes this design attractive to the handling of more abrasive slurry and higher pressure. The capital expenditure of this piston pump is substantially lower than that of an equivalent size diaphragm pump and offsets the piston and liner (wear) parts usage when pumping mildly abrasive slurry and/or moderate pressure.

The modular design shares the power end, the valves and pulsation dampener with the extensive range of GEHO piston diaphragm pumps.

Technically speaking, the TZP range of pumps handles the same wide performance envelope. As a result GEHO PUMPS can economically meet any flow sheet and duty requirement with either a piston or a piston diaphragm pump.

The design distinguishes from a so-called mud pump and from a flushed-plunger pump in that the stroke is longer, the stroke rate is lower, it utilises genuine slurry valves and all power end components have an inherent long wear life, even when the speed varies over a wide range.

The power end with cast frame transmits energy from an external gear reducer to the pistons by means of a forged steel, direct driven crankshaft, cross heads with replaceable guides and connecting rods. Clamp couplings and a special tool facilitate the removal of the piston and liner. Ceramic lined and hard surfaced liners are available to prolong the liner wear life.

A piston guide ring centres the cup seal in the liner. Spray flushing of the liner bore further reduces friction and wear. The poppet (check) valves are readily accessible for maintenance with oil-hydraulic release of the tapered cone valve seat.

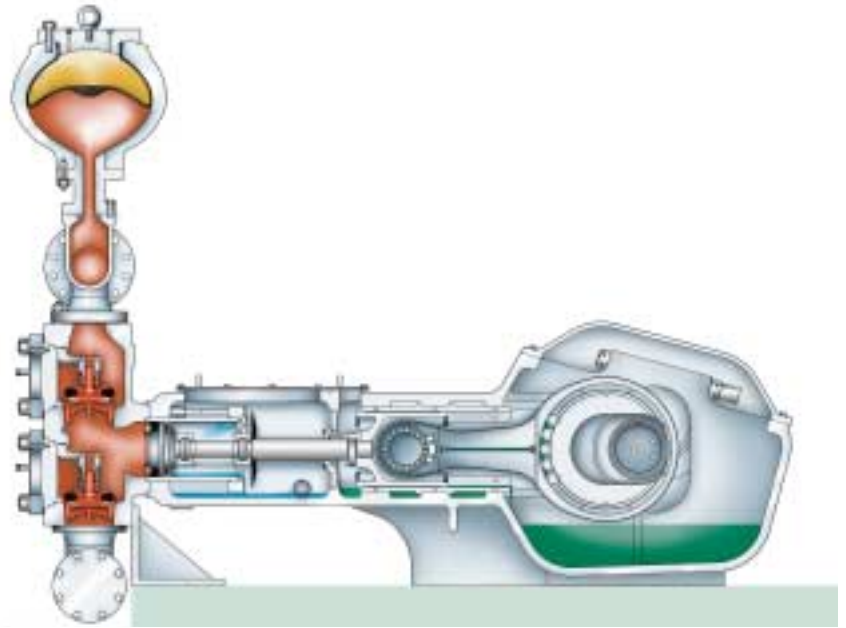

*Rio Capim Caulim in Brazil abandoned barge transport of kaolin from the mine to the beneficiation plant. Substantial savings were achieved with the installation of a 150 km slurry pipeline with 354 m³/h capacity. The 65%*C_w* slurry has a low abrasivity index - 15 Miller number. The reason for operating GEHO TZP 800 piston pumps is the 5,700 kPa pressure rating and 5 to 100% speed range enabling these pumps to unplug the pipeline as required.*



*Inco, Canada, operates a TZP 500 piston pump at 380 m underground to transport up to 74%*C_w* cemented sandfill to the stopes. The short life of the Copper Cliff backfill project did not justify a piston diaphragm style 'ore body booster pump', in spite the high abrasivity of the mixture. The pump is rated for 193 m³/h against 5,400 kPa and runs at 69 strokes per minute. The product is discharged against 238 m lift and 152 m horizontal. A pressure relief valve protects the water end from over-pressurisation and the power end with drive motor from overload. The pump is standard furnished with a nitrogen precharged discharge dampener.*

ZPM and TZPM – Duplex and triplex crankshaft driven piston diaphragm pump

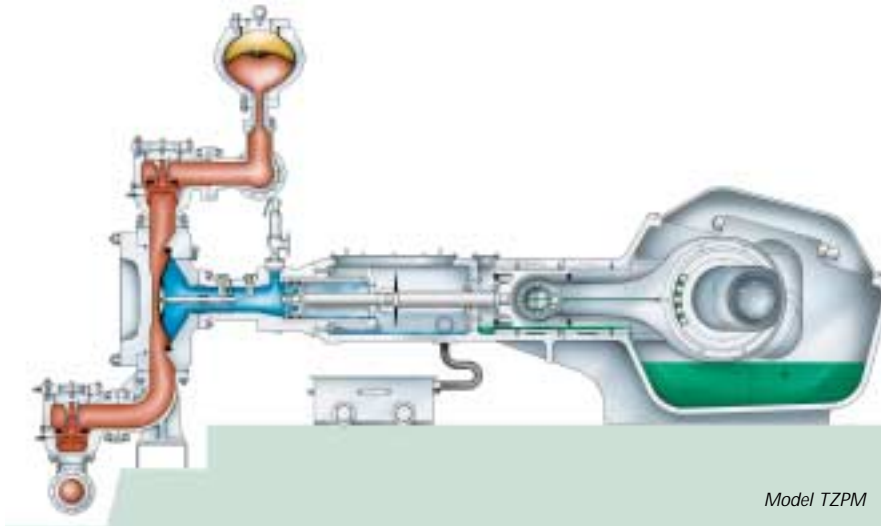

The principal difference between a piston and a piston diaphragm pump is the genuine diaphragm that protects the piston and liner from the sliding contact with the abrasive slurry.

The diaphragm is a pre-moulded design that eliminates elongation of the elastomer. Its long fatigue life allows for routine annual maintenance to be carried out. The diaphragm position is controlled in either direction of the stroke by adding or removing propelling fluid that fills the cavity between the piston and diaphragm. A guide rod connects to an insert and enables the position control.

A number of duty related elements cause the diaphragm not to flex uniformly. After quantifying the disturbing elements and empiric validation of the equations, we reliably select from the range of eight diaphragm sizes.

The only wear parts in the pump are the suction and discharge poppet valves. Various slurries require a different valve design and a unique combination of metal and elastomer components. These may be altered in operation as a result of a life cycle cost analysis.

A dampener with nitrogen precharged bladder reduces the pressure variation at the discharge flange for flow and acceleration induced pressure disturbances. The dampener volume is contingent upon the pump variables, the service and the residual pressure variation specified. A suction dampener or air vessel may serve to increase the Net Positive Suction Head (NPSH) available or for charge pump convenience.

GEHO PUMPS builds a complete range of double-acting (ZPM) and single-acting (TZPM) piston diaphragm pumps.

We select either type based on objective technical and commercial considerations.

The modular design enables combinations of various sizes of power end, piston, diaphragm, valve, etc. The proprietary selection guidelines (for example rod load, stroke rate, diaphragm load and valve velocity) evolve from technological development backed up by an unmatched performance track record.

Corrosive slurry carrier fluids may dictate the use of duplex, super duplex and Titanium material for the wetted pump components. Linings can be used as a precaution against microbially induced corrosion and high slurry abrasivity.



The high pressure and solids handling capability enable these ZPM 800 pumps at Northparkes copper-gold mine, Australia, to transport unsettled mine water from a raised bore sump to the storage dam, at the surface, in a single lift.

After the pioneering work at the Elura mine in Australia in 1982 'dirty-water' systems were refined and have become the preferred method to dewater underground mines.

Minera Alumbreira, Collahuasi, Escondida, Jianshan and Hy-Grade Pellets are examples of mineral slurry pipelines, which transport concentrate and ore over several hundred kilometres distance.

The Simplot 25,000 kPa pipeline pumps, operating since 1991, lead to the refinement and validation of a unique design code for pressure boundaries subject to cyclic load, erosion and fatigue.



GEHO duplex and triplex piston diaphragm pumps are used for storage of mine tailings. For surface disposal and for use underground in a backfill mix to support mining excavations. Wolfram pumps tungsten tailings at 65% Cw against 10,700 kPa. Their extreme (200 Miller number) abrasivity lead to the development of the unique UP-TIME® valve, which tripled the cone valve life.

The emphasis on the design and production of the high pressure water end components and bolted joints, in particular the diaphragm housing with diaphragm clamping rim, is on the avoidance of fatigue and stress corrosion due to the oscillating pressure. GEHO PUMPS has researched and validated a design code and selectively applies hydraulic stud tensioning, cold rolling and 'autofrettage'. With the creation of compression stress in the bore of the forged steel diaphragm housing, allowance for wear is obtained and the integrity over 25 MPa is preserved.

GEHO PUMPS, to our knowledge, is currently building the largest power end in the world. It takes over 1.100 kilo-Newton rod load at the relieving pressure. Reliability requires the use of a direct driven forged steel crankshaft, purpose built preloaded connecting rod bearings, hydraulic piston rod connections and a nodular cast iron frame. These pumps afford full pressure operation at five strokes per minute for pipeline unblocking.

A supervisory control panel with plc performs all logic, sequencing and alarm raising functions. The Gehographics® display allows the operator complete interaction with the pump and facilitates communication protocols.

The Heat-Barrier® design handles over 200°C slurry. A dropleg pipe connects the valves to the dead-headed diaphragm housing. The water jacket and oscillating separator sustain a low 80°C diaphragm temperature with minimum heat loss. Thermal pipe expansion is not restricted, as the pump is slide-mounted.

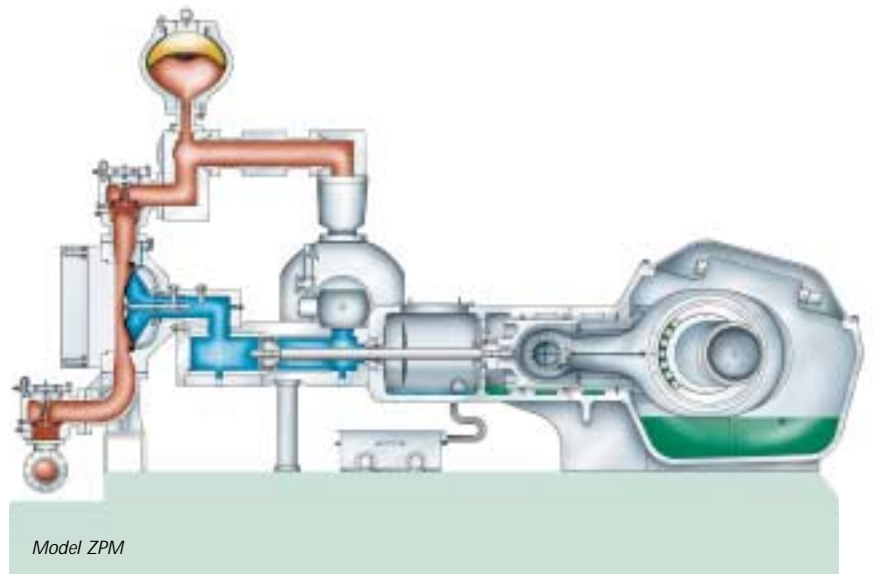

Alcan Gove and Nalco discharge a sloping cap on a wet deposit to facilitate reclamation and increase storage capacity. Alumina refineries also use GEHO pumps for feeding 110°C diasporic bauxite into the digester. The red mud is filtered/thickened for caustic recovery. GEHO's shear thinning, as required, allows the thixotropic paste to be pumped and stacked whilst capturing caustic.



Bayswater Power Station in Australia transports 74% Cw fly ash slurry 11 kilometres to a void. Pumping dense coal combustion residue and sloped disposal reduce cost, preserve flora, fauna and water quality and meet regulations. Syngas producers and IGCC power plants standard use GEHO pumps for transferring milled coal slurry and feeding gasifiers.

The Goldstrike and Twin Creeks gold ore pressure oxidation plants use autoclave feed pumps with vertical dropleg. The horizontal dropleg orientation results from the higher temperature, pressure and capacity requirements of the Murrin Murrin, Bulong and Rio Tuba nickel laterites refineries. R&D further extended the operating envelope and enhanced the performance, integrity and Outlast® valve life.

Patent warning: features of these products are protected by patents in various countries.

DHC and DHT – Hydraulic driven piston pump

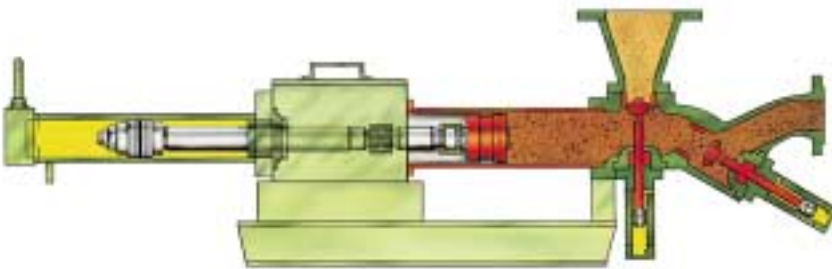

DHC - Piston pump with actuator assisted valves

The model DHC piston pump is fitted with large diameter, high lift, actuator assisted suction and discharge valves and handles rather viscous pastes and particles typically not larger than 15 mm. It uses the valve design from the diaphragm pump, except that the valve cone bolts directly onto the actuator rod. The actuator load and activation sequence is arranged such that a valve will not open against the pump discharge pressure. As a result the system is inherently protected against backflow, even if a valve is jammed open.



Kali + Salz in Germany ensures the structural integrity of salt caverns with paste backfill, which is a cemented high density and corrosive mixture of incinerator ash and superfluous caustic. The coated liner prevents crevice corrosion and loss of bonding and flaking of the standard chrome plating.

Where slurry consistency and particle size are beyond the limit of what a diaphragm pump can handle, consideration is given to hydraulic driven piston pumps. These are two cylinder, single-acting pumps with continuous water flush on the backside of the piston. These pumps are designed with a prerequisite low stroke rate, a low piston velocity and large flow areas, which also help to minimise wear. Cartridge mounted sensors are provided at either end of the hydraulic drive cylinders. Signals from opposed sensors/pistons enable a plc controlled stroke reversal and either piston to complete a full stroke. This method of leakage compensation enables the use of standard hydraulic piston seals, which afford a 5 to 100% capacity adjustment range. Larger size pumps use a linear transducer in lieu of sensors. It reduces the length and weight of the piston and cylinder and enables a full stroke length independent of the stroke rate.

The drive cylinder design, oil hydraulic flow sheet and plc programming aim to obtain a relatively smooth piston reversal and reduce hydraulically and mechanically induced loads. The larger size pumps accomplish piston pump stroke reversal by reversing the swash plate angle of the main oil pump(s) in lieu of manipulating a control valve. Without a detailed review of the slurry consistency, performance indicators and project requirements, it is usually difficult to decide between the two piston pump models.



An example of a large size DHC piston pump is found at Tarong North power station in Queensland. It handles 75%_{Cw} fly ash, which is on the verge of being pumpable with a diaphragm pump. A level controlled air vessel, compressor and air receiver help reduce the pressure pulsation level to 5%.



The piston is a metal body with guide ring and replaceable cup seal, which slides in a precision-machined hard chrome plated liner. The guide ring prevents the piston body from rubbing the liner, whilst the 0,4 mm chrome plating doubles the wear life and is less susceptible to accidental scoring and grooves.

DHT – Piston pump with transfer tube

The model DHT's pump water end comprises a hopper with transfer tube. This S-form pipe pivots on the discharge side whilst the inlet is intermediate between the opening of the paired cylinders. At the end of a suction stroke it covers the cylinder opening and isolates the filled cylinder from the suction hopper. During the subsequent discharge stroke, the piston forces the product through the tube into the discharge pipe. During switch over the tube partly overlaps and short-circuits the cylinders for a fraction of a second. When pumping a paste consistency, the backflow from discharge to hopper will be minimal and the resulting pressure pulsations, while not insignificant, will be quite acceptable in an adequately anchored piping system.

The tube inlet opening is fitted with a nozzle, which slides over a wear plate. Where the tailings are particularly abrasive, ceramics improve wear and galling resistance.

The size SR2 and SR3 hoppers are unique in that a hydraulic thrust load is generated, which pushes the tube against the wear plate. The tube nozzle is not required to move axially, but is flexibly mounted to compensate for uneven wear and misalignment. The swivel cylinders are positioned at a slight angle such that the nozzle to plate contact is maintained when the pump is idle. The tube turning lever is mounted on a tapered polygon, which provides a long term clearance-free and shock resistant fit.

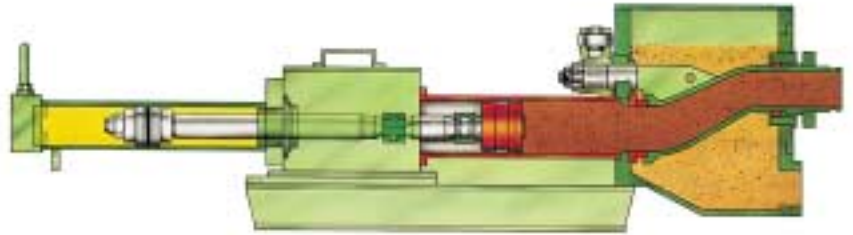

The El Indio gold mine backfill pump transports a 76% Cw cement based paste fill to the voids left by the mining operations. The paste mixer discharges into the hopper, which is open and tapered to suit the feed requirements. South Deep mine in South Africa transports backfill over 1250 metres from the underground crushing plant to the elevated stopes where the 85% Cw mixture of crushed waste and 15 mm aggregate helps to prevent rock bursts.



Municipalities have embraced the DHT pump for transferring dewatered biological sludge. The centrifuged sludge or filter cake is stocked in silos from where it is fed into incinerators. A twin screw feeder assists in feeding the pump. Often, water lube is employed to reduce the friction loss between the plug flow and wall of the discharge pipe. It is not uncommon to fit the feed pump with a hydraulic activated valve to reduce pressure pulsations due to flow fluctuations. These smaller pumps have a diverging transfer tube, splined shaft and manual end float adjustment.

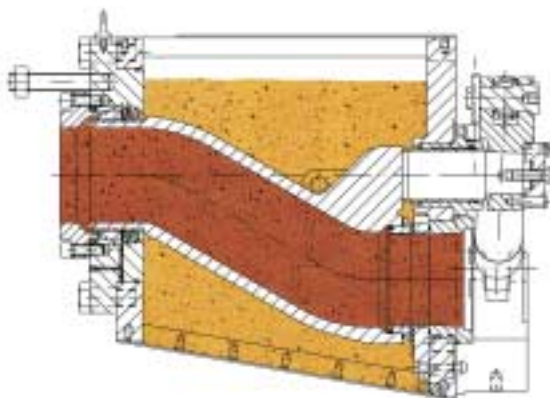

Positive tube thrust puts an end to manual tube end float adjustment and premature tube replacement due to washout of the tube and wear of the splined shaft.

Pump Systems

Surface disposal of tailings, as a thickened paste, as opposed to conventional slurry deposition in a pond, offers considerable advantages and reduces the environmental impact. GEHO PUMPS has played an active role in the development, promotion and global acceptance of the high concentration tailings disposal system. The pioneering red mud (alumina tailings) Thickened Tailings Disposal (TTD) systems were the result of alumina producers and key equipment suppliers working in close partnership. They combined efforts in the development of the concept, laboratory testing, process design, equipment layout, process control, in-situ verification and adjustment of parameters and the instruction and training of operators. As result, Thickened Tailings Disposal systems are now actively sought for the deposition of mine tailings and the residue from coal combustion.

We have the experience, testing and analysis capability to verify that a stackable paste consistency is indeed pumpable with appropriate flow behaviour. It is believed that previous difficulties experienced with the functioning and performance of disposal systems can largely be avoided with current technology. The emphasis is on a co-ordinated approach; calling on expertise and experience available with GEHO PUMPS, the thickener supplier and the disposal expert. In response to demands from the industry we have structured and staffed a Pump Systems Department to perform co-ordination tasks and supervise the local engineering contractor charged with detailed engineering, construction and commissioning of a Thickened Tailings Disposal system. We can increase that service by offering a range of complementary products.



The Elektrarna Ledvice power plant deposits residue from coal combustion and flue gas desulphurisation at a distance of 4700 metres against the slopes of an open pit. We met the challenge to build a dry disposal system for a hardening (from CaO reaction) slurry with entrained crushed slag in a rather humid and temperature climate. The disposal system comprises the preparation, transportation, distribution and disposal of the high density slurry. Detailed engineering and construction was subcontracted to selected Czech companies. GEHO PUMPS undertook the conceptual design, basic engineering and supplied all critical components.



Tower discharge of thickened red mud – ‘dry stacking’ – Alcan Gove, Australia.

The Nalco alumina refinery in India commissioned a Thickened Tailings Disposal system in 2002. GEHO diaphragm pumps transport red mud from the Alcan type paste thickeners by a 6700 m surface pipeline to the far end of the existing conventional wet pond. The pond is provided with a sloped thickened tailings capping that increases the life and storage volume. The feasibility study was jointly undertaken by GEHO PUMPS, Eimco and Robinsky, who developed the controlled discharge and reclamation schedule. GEHO PUMPS was charged with the basic design, the supply of most hardware, schedule, progress reporting, the supervision of the construction by the Indian contractor and assumed responsibility for the quality and performance. The detailed engineering including control software was made on the basis of a layout, process and instrumentation diagram and an operating and control philosophy.

Aftermarket support

By aligning our own objectives with those of our end-user customers, we are forming long-term mutually beneficial partnerships. We provide comprehensive support under flexible agreements tailored to customer needs.

The unique design and technology of a GEHO pump warrants that we supervise its installation and start-up. We also provide on-site technical product training to enhance personnel performance in maintenance and operations. Participants review and exercise proper start-up, shutdown, maintenance and troubleshooting procedures and are taught about the function and operation of critical pump components.

The wear pattern and wear rate of a slurry pump poppet valve depend on the service. We have a variety of advanced materials and designs available and are dedicated to working with the end-user to ensure a most economical mean time between valve replacements for the plant.

Wear resistant lining and other repair techniques developed in conjunction with the end-users have prolonged the life of slurry pump wet-end components that are subject to abrasion.

Quality parts are available from our works, regional parts distribution centers or from an agreed consignment. Close co-operation with the customer in matching the supply chain to the anticipated need has the potential to reduce parts inventory while ensuring the availability of the wear and maintenance spare parts to the customer.



Our customer relations are long term, committed and close.

Around-the-clock technical assistance provides a quick response to any urgent query and operational issue. GEHO reps make site visits at agreed intervals to review and discuss all key pump operation's issues and the life cycle pumping equipment needs. Our global customers consistently use our professional qualified engineers to provide equipment checks and perform essential maintenance, retrofits and upgrades. In our commitment and focus to meet the end-user needs and expectations we give, when consulted, an expert opinion on problems related to slurry and the slurry handling system.



The range of poppet valves is continually being extended through research and development in wear and corrosion resistant materials and through improvements to the design.



GEHO pumps and replacement parts have a deserved reputation for durability and reliability.



From design and installation, through service, maintenance and upgrade, we are committed to enhance whole life cycle performance to the advantage of existing and new customers.



The ORIGINAL GEHO diaphragm

Weir Netherlands b.v.

P.O. Box 249, 5900 AE Venlo, the Netherlands
Egtenrayseweg 9, NL-5928 PH Venlo
4495
Registration No.: 12032525

Tel: +31 (0)77 389 52 00
Fax: +31 (0)77 382 48 44
Email: weir@weir.nl
www.weir.nl

Excellent
Engineering
Solutions

